

# 加热器端差对机组热经济性影响的定量分析方法

刘 强<sup>1</sup>, 郭民臣<sup>2</sup>, 田永伟<sup>3</sup>, 王毅林<sup>1</sup>

(1. 南京工程学院 动力系, 江苏 南京 211167; 2 华北电力大学 动力系, 北京 102206;

3. 东南大学 火电机组振动国家工程研究中心, 江苏 南京 210096)

**摘 要:**建立了定流量下加热器端差对机组热经济性影响的数学模型。该模型针对加热器的不同类型进行了讨论, 应用时不再需要单独计算端差变化对锅炉吸热量的影响, 并全面考虑了热力系统的结构特点及辅助汽水系统, 从整体上定量分析加热器端差对机组热经济性的影响, 为火电机组节能降耗以及热力系统定量分析提供了理论依据。对某 600 MW 机组进行了算例分析, 表明端差越大, 机组的热经济性越低; 端差越小, 机组的热经济性越高。

**关 键 词:** 热力系统; 加热器; 端差; 热经济性; 矩阵法

中图分类号: TK212

文献标识码: A

## 引 言

加热器端差是指加热蒸汽的饱和温度与加热器出口水温之差。在实际运行中, 端差的存在和变化虽没有发生直接的明显热损失, 但是增加了热交换的不可逆性, 产生了额外的冷源损失, 降低了装置的热经济性<sup>[1~3]</sup>。因此分析加热器端差对机组热经济性的影响对电厂节能与运行有很大的现实意义。文献<sup>[1~2]</sup>运用等效热降法提出了端差对机组热经济性影响的计算模型; 矩阵法方面, 文献<sup>[3]</sup>中构建了加热器端差对汽轮机做功量、锅炉吸热量及机组热经济性影响的计算模型, 为计算端差对机组热经济性的影响提供了新的方法。本文通过对机组绝对内效率方程式进行微分, 并基于热力系统结构矩阵对加热器不同连接形式进行讨论, 直接分析端差对机组热经济性的影响。

## 1 加热器端差影响机组热经济性的物理模型

当第  $i$  级加热器在运行中出现给水加热不足, 则体现在该级加热器出口水焓  $\bar{t}_i$  变化  $\Delta \bar{t}_i$ , 若压力高

一级(第  $i-1$  级)是不带疏水冷却器的表面式加热器, 则该级端差不会影响第  $i-1$  级的疏水焓; 若第  $i-1$  级加热器是带疏水冷却器的表面式加热器, 则第  $i-1$  级加热器疏水焓变化  $\Delta \bar{t}_{s(i-1)}$ , 并有  $\Delta \bar{t}_{s(i-1)} = \Delta \bar{t}_i$ , 即  $\bar{t}_{s(i-1)}$  的变化同  $\bar{t}_i$  一致, 所以只选择  $\bar{t}_i$  为自变量, 研究定流量条件下端差对机组热经济性的影响, 并规定端差增大  $\Delta \bar{t}_i$  为负, 反之  $\Delta \bar{t}_i$  为正。



图 1 端差影响示意图

## 2 定流量条件下加热器端差对机组热经济性影响的数学模型

汽轮机做功表达式<sup>[3~5]</sup>:

$$w = h_0 - h_c + \sigma - \alpha^T h^\sigma - w_f \quad (1)$$

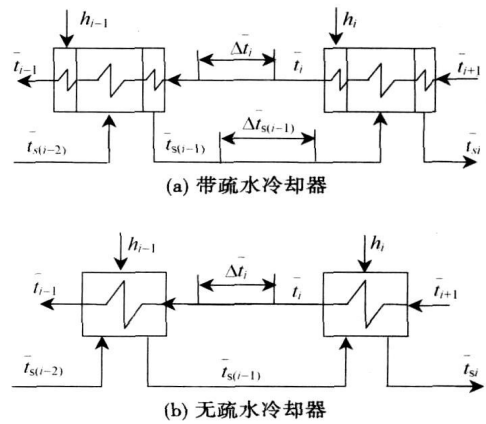
循环中单位工质的热耗量<sup>[3~5]</sup>:

$$\begin{aligned} q_0 + q_{rh} &= h_0 - \bar{t}_1 + \alpha_{th} \sigma \\ &= h_0 - \bar{t}_1 + \sigma - (\alpha^T + \alpha_f^T) \sigma \end{aligned} \quad (2)$$

式中:  $h_0, h_c, \sigma$ —主蒸汽焓, 排汽焓和 1 kg 蒸汽再热吸热量;  $w_f$ —轴封漏汽等在汽轮机内的做功不足;  $h^\sigma = [h_1 - h_c + \sigma \dots h_m - h_c + \sigma h_{m+1} - h_c \dots h_z -$





抽汽效率差值较大。

## 4 结 论

(1) 基于热力系统结构矩阵,建立了加热器端差对机组热经济性影响的计算模型。该模型讨论了加热器不同类型以及连接方式下的具体表达式,这为火电机组节能降耗以及热力系统定量分析提供了理论依据。

(2) 该数学模型不需要单独计算因端差引起的锅炉吸热量的变化,计算简洁。运用本文的计算模型对某 600 MW 机组分析加热器端差对机组热经济性的影响,并同热平衡法和等效热降法进行了比较,结果一致。

(3) 该模型全面考虑了热力系统的结构特点及辅助汽水系统,从整体上对机组进行定量分析,真实反映了端差对机组热经济性的影响,通用性较强。

## 参考文献:

- [1] 林万超. 火电厂热系统节能理论[M]. 西安:西安交通大学出版社,1994.
- [2] 严俊杰, 邢秦安, 林万超, 等. 火电厂热力系统经济性诊断理论及应用[M]. 西安:西安交通大学出版社,2000.
- [3] 张学蕾, 王松龄, 陈海平, 等. 加热器端差对机组热经济性影响的通用计算模型[J]. 中国电机工程学报, 2005, 25(4): 166—171.
- [4] 郭民臣, 魏 楠, 杨勇平. 热耗变换系数、抽汽效率与主循环效率[J]. 中国电机工程学报, 2001, 21(10): 83—87.
- [5] 刘 强, 郭民臣, 刘鹏飞. 抽汽压损对机组热经济性的影响[J]. 中国电机工程学报, 2007, 27(8): 59—63.
- [6] 郭民臣, 王清照, 魏 楠, 等. 电厂热力系统矩阵分析方法的改进[J]. 热能动力工程, 1997, 12(2): 103—106.
- [7] 郭民臣, 魏 楠. 电厂热力系统矩阵热平衡方程式及其应用[J]. 动力工程, 2002, 22(2): 1733—1738.
- [8] 郑体宽. 热力发电厂[M]. 北京:中国电力出版社,2001.

(编辑 渠 源)

## 新 技 术

# 额定 165 MW 和 41% 效率的闭式循环核装置

据《Gas Turbine World》2007 年 3~4 月号报道,南非 Eskom 拟 2008 年建造一台 165 MW 闭式循环氦气轮机示范装置,于 2012 年启动运行,该装置将由高温氦气冷却卵石床模块式反应堆供给动力。

主要的设计和特性:

涡轮机轮系:单轴氦气涡轮、高压和低压氦气压气机、用于 50/60 Hz 发电机的减速齿轮传动装置。

闭式循环:示范装置设计的额定值为 165 MW 全负荷输出功率和 41.2% 效率。

预算价格:不包括开发的费用,估计示范装置约 2.8 亿美元(2007 年 1 月美元价)或 1700 美元/kW。

估计的电力成本:根据当前的设备和轴燃料价格,预计的电力成本保守估计约为 55 美元/(MWh)。

165 MW 装置围绕一个高温氦气冷却的 400 MW 反应堆堆芯设计,基于直接的布雷顿闭路循环,该反应堆为一台由三菱重工研制的单轴氦气轮机提供动力。

涡轮直接驱动用于氦气流的高压和低压压气机,并通过用于 50/60 Hz 电力生产的行星齿轮减速装置驱动发电机。

水平的单轴氦气轮机采用了滑油润滑轴承,而不是电磁轴承。

经过压缩的氦气,以 185 kg/s 流量、9 MPa 压力和 500 °C 温度进入反应堆,冷却反应堆堆芯。在反应堆中,氦气被加热到约 900 °C,然后回到动力转换单元。

(吉桂明 供稿)

两种能衡式蒸汽干度仪的研究=A Study of Two Types of Energy-balanced Steam Dryness-fraction Measuring Instrument[刊, 汉]/LI Shi-wu, KANG Qin (College of Power and Energy Source, Northwestern Polytechnical University, Xi'an, China, Post Code: 710072)//Journal of Engineering for Thermal Energy &Power. — 2007, 22(5). — 517~520

The steam dryness fraction is a quality parameter of steam, which needs to be real-time measured and controlled in many industrial production processes. Analyzed are the current measuring methods and instruments of steam dryness-fraction. On the basis of energy conservation theory and measurement theory of hybrid and condensing type steam dryness-fraction, two types of energy-balanced steam dryness-fraction measuring meter have been developed. Furthermore, their measurement accuracy is quantitatively analyzed and from the viewpoint of practical stability the authors have concluded that the condensing type steam dryness-fraction meter is superior to the hybrid type. To verify measurement accuracy, a steam dryness-fraction test rig has been set up. The tests not only show that the energy-balanced condensing type meter has attained an accuracy higher than 98% but also indicate that it is stable, accurate and practical. **Key words:** steam dryness-fraction, dryness-fraction measuring meter, measurement accuracy

加热器端差对机组热经济性影响的定量分析方法=A Method for the Quantitative Analysis of the Impact of Terminal Temperature Differences of Heaters on Thermal Effectiveness of Power Generating Units[刊, 汉]/LIU Qiang, WANG Yi-lin (Power Department, Nanjing Institute of Technology, Nanjing, China, Post Code: 211167), GUO Min-chen (Power Department, North China Electric Power University, Beijing, China, Post Code: 102206), TIAN Yong-wei (National Engineering Research Center of Thermal Power Plant Vibrations, Southeast University, Nanjing, China, Post Code: 210096) //Journal of Engineering for Thermal Energy &Power. — 2007, 22(5). — 521~524

A mathematical model has been established to analyze the impact of terminal temperature differences of heaters under a given flow rate on the thermal effectiveness of power generating units. By using the model, different types of heaters are discussed and it is no longer necessary to independently calculate the influence of the change in terminal temperature differences on the heat absorption quantity of boilers. By taking into account in a comprehensive way the structural features of a thermal system and also an auxiliary steam-water system, an integral and quantitative analysis was performed of the impact of the terminal temperature differences of heaters on thermal effectiveness of power generating units. The foregoing can well provide a theoretical basis for achieving energy saving, reducing coal consumption of thermal power plants as well as performing a quantitative analysis of the thermal systems. The analysis of a calculation example for a 600 MW power generating unit shows that the greater the terminal differences, the lower the thermal effectiveness of the power plant and the smaller the terminal differences, the higher the thermal effectiveness of the plant. **Key words:** thermal system, terminal temperature difference, thermal effectiveness, matrix method

自激励脉动燃烧式锅炉设计方法=A Method for the Design of Self-excited Pulsation-combustion Boilers[刊, 汉]/LI Hua, DENG Kai, ZHONG Ying-jie, et al (College of Electromechanical Engineering, Zhejiang University of Technology, Hangzhou, China, Post Code: 310014)//Journal of Engineering for Thermal Energy &Power. — 2007, 22(5). — 525~528

The use of self-excited pulsation combustion technology to a boiler can not only enhance its thermodynamic performance but also reduce its emission of flue gas pollutants. Concerning this issue, a theoretical study of pulsation boiler design and its experimental verification has been performed. On the basis of analyzing the restrictions encountered during the use of the pulsation combustion technology to boilers, the pulsation boiler design criteria can be given as follows: the burners should be located at a flow passage 1/4 length of distance from the fan inlet, the total area of the cross sections of various flue pipes should be 20% to 30% of the cross section area of the furnace with the diameter of a tail pipe being determined by the pulsation frequency. The effective flow area of various gas flow passages should be equal. According to the above design criteria, a pulsation boiler has been designed and manufactured and a thermodynamic performance test con-