

# 边界元法在气冷涡轮叶栅气热耦合计算中的应用

王振峰, 黄洪雁, 唐洪飞, 韩万金

(哈尔滨工业大学 能源科学与工程学院, 黑龙江 哈尔滨 150001)

**摘 要:** 将边界元计算方法应用到三维 N-S 方程求解程序中, 流体部分采用有限差分法求解 N-S 方程, 边界元法求解固体区域热传导方程。开发气热耦合计算程序对 NASA—MarkII 高压气冷涡轮叶栅热环境进行气热耦合分析。利用边界元法特有的优势(降维、解析与离散相结合的特点)避免了固体区域的网格生成和内部节点求解工作, 提高了计算精度。结果表明, 耦合计算程序能够高效、准确求解多场的气热耦合问题, 计算结果与实验结果吻合的较好, 二者平均误差为 3%。

**关 键 词:** 燃气涡轮; 空气冷却; 气热耦合; 边界元法; 有限差分法

中图分类号: TK472 文献标识码: A

## 引 言

随着对涡轮发动机性能要求越来越高, 涡轮叶栅内热环境分析变得非常重要。因此, 在涡轮发动机设计过程中, 除了要考虑气动效率外, 涡轮叶栅内部高温部件的温度分布成为另一个重要的因素。过去, 大多数研究方法基于有限差分、有限元或有限体积法, 这些计算方法需要同时计算固体和流体区域的网格单元, 在现代涡轮设计领域中为了提高气动性能, 涡轮叶片通常具有弯、扭、掠等几何特征, 同时冷却技术的应用, 使涡轮叶片具有气膜孔及复杂的冷却通道等几何特征, 叶片特殊的几何轮廓对其网格划分工作带来很大的挑战, 网格质量的好坏对耦合计算精度有很大的影响。近几年, 气热耦合计算方法成为透平机械领域中热环境分析的有效工具<sup>[1-2]</sup>, 一些研究人员已经开始应用耦合热分析方法研究涡轮叶栅的气热耦合问题<sup>[3-5]</sup>。国外学者 Li 和 Kassab 将边界元计算方法应用于气热耦合计算程序中<sup>[6]</sup>, 对气膜冷却涡轮叶片进行了气热耦合计算, 利用了边界元法特有的优势(降维、解析与离散相结合的特点)使得计算前处理和计算时间缩短,

提高了计算精度<sup>[7-8]</sup>。文献 [9] 应用边界元法对二维燃气气冷涡轮进行了气热耦合计算, 得出的计算结果更接涡轮内部真实热环境。本研究结合边界元法和有限差分法, 利用边界元法进行耦合热分析计算的优势, 对 NASA—MarkII 高压燃气涡轮叶栅进行了气热耦合计算, 其计算结果与实验结果较为接近。

## 1 数值方法

### 1.1 流体区域

流体区域计算程序基于可压 Navier—Stokes 方程进行编写, 采用有限差分方法求解, 差分格式为具有 TVD 性质的三阶精度 Godunov 格式, 湍流模型为代数 B—L 模型, 湍流普朗特数为 0.9 层流普朗特数为 0.72。控制方程包括质量方程、动量方程和能量方程, 具体形式可参考文献 [10]。

### 1.2 固体区域

固体区域计算程序采用边界元法计算拉普拉斯方程, 边界元法是将问题的控制方程转换成边界上的积分方程, 然后引入位于边界上的有限个单元将积分方程离散求解。

稳态热传导问题以不存在内热源的拉普拉斯方程作为控制方程:

$$\nabla^2 u = 0 \tag{1}$$

边界条件:

$$u = \bar{u} \quad \in \Gamma_1$$

$$\frac{\partial u}{\partial n} + \frac{\alpha}{k} u = \bar{q} \quad \in \Gamma_2$$

式中:  $k$   $\alpha$ —固体的导热系数和固体与流体之间的对流换热系数。

边界元法应用加权余量法将拉普拉斯方程转化为表面积分方程, 基本解为自由空间的格林函数, 对

收稿日期: 2009-02-23 修订日期: 2010-01-13

资助项目: 国家自然科学基金资助项目(50706009 50576017)

作者简介: 王振峰(1980—), 男, 内蒙古赤峰人, 哈尔滨工业大学博士研究生。

于三维边界元法,应用四边形单元将边界进行剖分,从而得到积分方程的离散算式。在求出所有未知边界点函数值后,可用内点积分公式及相似的数值计算方法求出任意内点处的位势值<sup>[8]</sup>,则:

$$u_i = \sum_{j=1}^N (\int_{\Gamma_j} u^* d\Gamma) q_j - \sum_{j=1}^N (\int_{\Gamma_j} \frac{\partial u^*}{\partial n} d\Gamma) q_j \quad (2)$$

1.3 气热耦合算法

在现代燃气涡轮设计中,传统的涡轮热分析方法已经被气热耦合方法代替,本研究应用边界元法和有限差分法对 NASA—Mark II叶片<sup>[11]</sup>进行流体区与固体区的气热耦合计算。采用二维边界元法的气热耦合问题在文献[9]中已经进行阐述,其中包括对边界元程序的验证工作。进而本文采用三维边界元法的气热耦合程序对涡轮叶栅热环境的数值模拟。

耦合计算程序(HIT-NS-3DBEM Code)由流体区域程序和固体区域程序两部分编写而成,流体程序(HIT-NS Code)求解流体区域 N-S 方程,采用 B-L 湍流模型,固体程序(3DBEM Code)采用三维边界元方法求解固体区域稳态热传导问题。耦合程序计算过程是:首先,在流体和固体交界面上给定初始的绝热边界条件,流体程序计算所得的流体和固体交界面温度作为固体程序计算的边界条件;其次,边界元程序计算固体区域稳态热传导问题,得出交界面的热流分布;最后,交界面上的热流值再传递给流体程序作为下一代步计算的边界条件。这个过程不断反复直到获得一个稳态的解,迭代收敛的标准是流体与固体交界面上温度和热流的连续。

2 几何模型和边界条件

2.1 NASA—Mark II叶栅几何结构及网格划分

耦合计算程序对 Mark II燃气涡轮流道和叶片区域进行气热耦合求解,Mark II叶片是一个高压涡轮导向叶栅,其特点是具有 10个径向冷却通道的直叶片,图 1给出了 Mark II叶栅的几何结构图。

图 2为 Mark II涡轮叶栅耦合换热计算的网格划分图,采用 H-O-H型结构化网格,在流固耦合交界面附近对网格进行局部加密处理。区别于有限差分法和有限元方法,边界元法在求解固体区域热传导问题时不需要固体区域网格,因此在叶片的固体区域不需要进行网格划分。

2.2 边界条件

耦合程序(HIT-NS-3DBEM Code)计算时的边界条件取自 NASA—Mark II叶栅的某一实验工况

条件,边界条件包括叶栅进口总温、总压,叶栅出口静压,叶栅进出口雷诺数和出口湍流度,表 1给出了边界条件的详细数据。



图 1 Mark II叶片几何结构图



图 2 Mark II叶栅计算网格图

表 1 MARK II 叶栅边界条件

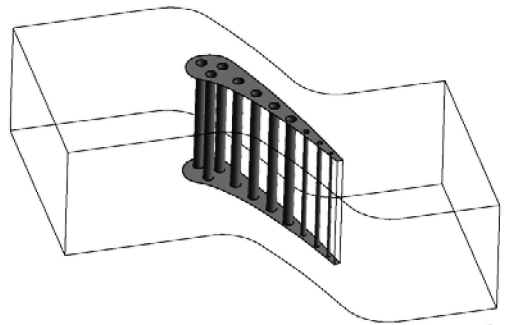
Run	进口总压 /MPa	进口总温 /K	出口静压 /MPa	出口湍流度 /%
43	0.342 268	784	0.210 495	6.5

固体叶片的热传导系数随着温度变化而变化,变化规律式为:

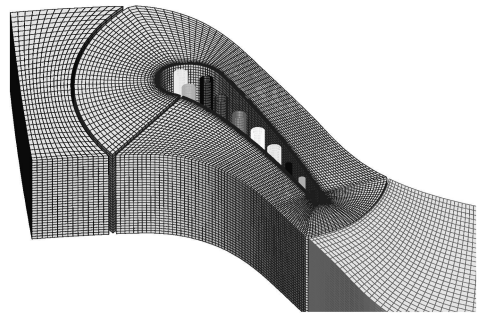
$$\lambda_s(T) = 0.0115 * T + 9.9105 \quad (3)$$

式中:  $\lambda_s$ —固体的热传导系数; T—温度。

3 计算结果比较分析

3.1 涡轮叶栅流动特性

图 3和图 4分别给出了叶展中部叶片表面压力分布及 S 流面马赫数分布,由图可知,实验和程序计算得出的叶片表面压力分布曲线基本吻合。在叶片压力面侧,从前缘至尾缘出口压力值逐渐降低,压力的变化趋势与马赫数的分布情况比较吻合,随着压力逐渐降低,流体马赫数逐渐增大;在叶片吸力面侧,从前缘滞止点至 43% 轴向弦长区间,随着流体压力的急剧降低,马赫数逐渐增加,在图 4中的 A

区附近, 由于强激波的存在, 使得气流速度变化较大, 在叶片表面压力分布图上可见, 此区域附近压力开始增大, 同时气流流速降低。结合两图可以给出流体在叶栅中的流动特性, 同时能够说明采用边界元方法的耦合计算程序对于燃气涡轮叶栅的流动分析计算结果比较准确。



图 3 叶展中部叶片表面压力分布



图 4 叶展中部 S 流面马赫数分布

### 3.2 涡轮叶栅换热特性

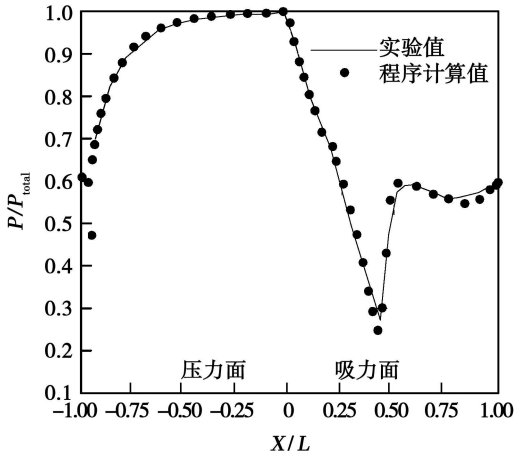
图 5 给出了 Mark II 叶栅中部叶展处实验、程序计算及绝热壁面条件下叶片表面的温度分布图, 比较了绝热壁面条件和实验结果所得的叶片表面温度分布, 可以看出, 二者在压力面和吸力面上的温度值具有 30% 的误差, 由此说明在研究燃气涡轮叶栅温度场分布时, 忽略流体与叶片的对流换热、固体内部热传导及冷气与叶片对流换热过程的非耦合处理方法是 不准确的。比较程序计算结果与实验结果可以看出, 二者叶片表面温度分布更加接近, 由此得出, 气热耦合计算在涡轮叶片温度场, 计算结果更加接

近涡轮叶栅真实热环境。在叶片压力面侧, 二者的温度分布较为接近, 最大误差仅为 3%, 计算程序能够准确地模拟冷却气流经冷却通道导致的温度波动效果。在叶片吸力面侧, 从前缘滞止点到 20% 轴向弦长区间, 二者温度分布较为接近; 从 20% 轴向弦长至 40% 轴向弦长区间, 程序计算结果较实验结果略高, 最大误差仅为 7%。其原因是从 40% 轴向弦长至尾缘区域, 耦合程序对叶片温度场的模拟较为准确, 较选用转捩模型的 CFX 软件对叶片温度场的模拟更为准确<sup>[12]</sup>。

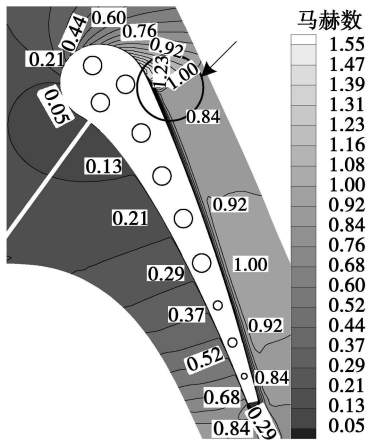

图 5 叶展中部叶片表面温度分布



图 6 叶展中部 S 流面温度分布

图 6 给出了叶展中部 S 流面温度分布图, 流经 10 个冷却通道的冷气使得叶片的温度较低, 而叶片壁面附面层外的流体温度仍然较高, 因此叶片壁面附面层内部的温度梯度较大, 对此区域传热特性研究的正确性决定着涡轮叶栅热环境分析结果的准确性。

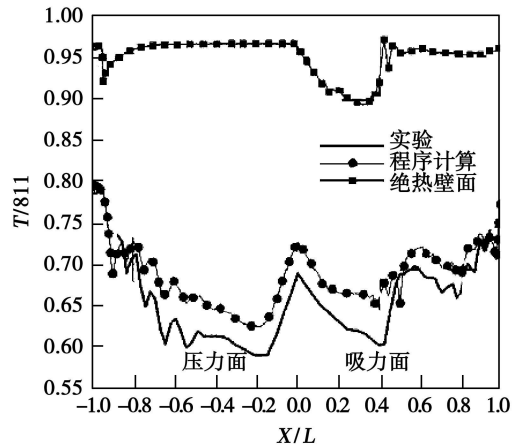
图 7 给出了绝热壁面条件和气热耦合条件下得出的叶片温度分布图, 两种情况下叶片温度值相差

很大,由此可以得出,在涡轮叶栅的温度场分析过程中采用气热耦合分析方法是必要的。

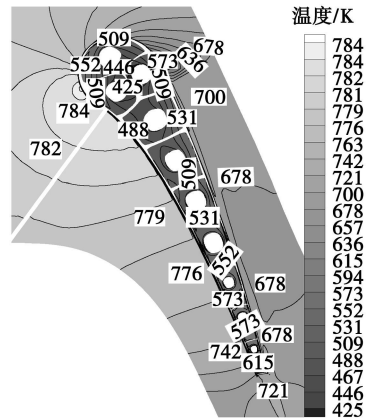

图 7 绝热条件和耦合条件下叶片温度分布

### 4 结论

(1)采用边界元计算方法的耦合换热计算,避免了复杂的涡轮叶片几何体(弯、扭、掠、气膜孔及复杂的冷却通道等几何特征)的网格生成和固体内部节点的求解工作。

(2)耦合计算程序中采用的 B-L 代数湍流模型对于大曲率绕流及有分离的流动预测不够准确,不能准确预测出吸力面上的转捩区域的传热特性。

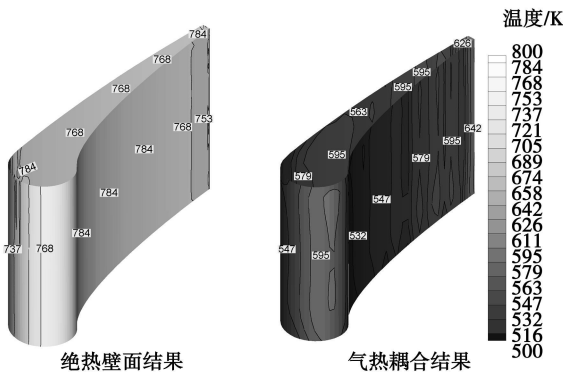
(3)自主开发的三阶精度气热耦合计算程序能够高效、准确求解多场的气热耦合问题,计算结果与实验结果吻合的较好,二者平均误差仅在 3%。

### 参考文献:

[ 1 ] HEDMANN J D KASSAB A J SIENITHORSSON E Conjugate

heat transfer effects on a realistic film-cooled turbine vaneq Rj. ASME Paper GT2003-38553 2003.

[ 2 ] RAHAM C P CAVALLERIR J Coupled Finite Volume and Boundary Element Analysis of Conjugate Heat Transfer Problems Rj. AIAA 96-1809 1996

[ 3 ] DIVO E SIENITHORSSON E KASSAB A J et al An iterative BEM/FVM protocol for steady-state multi-dimensional conjugate heat transfer in compressible flows J. Engineering Analysis with Boundary Elements 2002 26 447-454.

[ 4 ] TAKAHSHIT WATANABE K TAKAHSHIT T Thermal conjugate analysis of a first stage blade in a gas turbineq Rj. ASME Paper 2000-GT-251 2000

[ 5 ] RGBY D L LEP COVSKY J Conjugate heat transfer analysis of internally cooled configurationsq Rj. ASME Paper 2001-GT-405 2001

[ 6 ] KASSAB A J DIVO E HEDMANN J D et al BEM/FVM conjugate heat transfer analysis of a three-dimensional film-cooled turbine bladeq J. International Journal for Numerical Methods in Heat Transfer and Fluid Flow 2003 13(5): 581-610.

[ 7 ] BREBBA C A TELLES J C WROBEL L C Boundary element techniques Mj. New York Springer-Verlag 1985.

[ 8 ] 杨德全, 赵忠生. 边界元理论及应用 [ M ]. 北京: 北京理工大学出版社, 2006.

[ 9 ] WANG Z F YAN P G GUO Z Y et al BEM/FVM conjugate heat transfer analysis of a two-dimensional air-cooled turbine blade boundary layerq J. Journal of Thermal Science 2008 17(3): 199-206

[ 10 ] 王松涛. 叶轮机三维粘性流动数值方法与弯叶栅内涡系结构的研究 [ D ]. 哈尔滨: 哈尔滨工业大学, 1999

[ 11 ] HYLTON L D MHELCM S TUMER E R et al Analytical and experimental evaluation of the heat transfer distribution over the surfaces of turbine vanesq Rj. NASA Technical Report ASA-CR-1680 1983

[ 12 ] 董平, 黄洪雁, 冯国泰. 高压燃气涡轮径向内冷叶片气热耦合的数值分析 [ J ]. 航空动力学报, 2008 23(2): 201-207.

(本文责任编辑 刘伟)

### 新技术、新工艺

## 利用废弃核潜艇反应堆装置的工艺流程

据《Судо строение》2009年3-4月报道,大多数退出运行的核潜艇的核动力装置基本上处在良好的状态,核动力装置的主要设备还没有达到规定的寿命指标。

在浮动的原子能热电站中,利用已退出运行的现成反应堆舱和汽轮机舱看来在经济上是合理的,核动力的发展计划规定要建造这种原子能热电站。

论述了有关利用已废弃核潜艇的核动力装置用于浮动的原子能热电站动力模块的问题的解决方法。

利用已废弃核潜艇核动力装置的工艺流程允许建造浮动的原子能热电站,其降低建造费用并缩短建造和投资回收的时间、大大减少放射性废弃物的数量,并利用它们的费用、充分发挥被废弃核潜艇核动力装置的潜力。

为了实施上述工艺流程,必须在近期开展科研和实验设计工作,以便论证把已废弃核潜艇反应堆舱用于浮动的原子能热电站的工程中。

(吉桂明 摘译)

表面活性剂减阻溶液湍流传热结构研究进展 = Research Advances Concerning the Heat transfer Turbulent Structure of Drag-reducing Surfactant Solutions [刊, 汉] / PANG Ming-jun, WEI Jin-jia (National Key Laboratory on Multi-Phase Flows in Power Engineering, Xian Jiaotong University, Xian, China, Post Code: 710049), LI Feng-chen (College of Energy Science and Engineering, Harbin Institute of Technology, Harbin, China, Post Code: 150001) // Journal of Engineering for Thermal Energy & Power — 2010, 25(2). — 127 ~ 133

The drag-reducing surfactants feature a long service life and produce no degradations when compared with various polymer additives, and have been widely used in centralized district heating (cooling) systems. As the surfactants reduce the fluid turbulent friction drag, they will also deteriorate the heat transfer performance of the surfactant solution. To expand their applications in the heat transfer domain and understand the cause of the deterioration in heat transfer performance, some experimental study and theoretical analyses have been conducted of the turbulent heat transfer structures for the surfactant solutions. However, the foregoing is still at an exploratory stage and no final conclusion has been drawn. To facilitate further study, an analysis with a summarizing-up was performed of the recent research on turbulent heat transfer structures and of the achievements made both at home and abroad. Moreover, the problems existing in the current research were also analyzed with personal viewpoints being presented for future studies. Key words: surfactant, flow drag reduction, heat transfer structure, spt

超微涡轮动叶栅叶顶间隙对流场影响的数值模拟 = Numerical Simulation of the Influence of the Blade Tip Clearance on the Flow Field of an Ultramicro Turbine Rotating Cascade [刊, 汉] / HU Jian-jun, SUN Xi-shan (College of Architectural Engineering and Mechanics, Yanshan University, Qinhuangdao, China, Post Code: 066004), XU Jin-liang (Guangzhou Energy Source Research Institute, Chinese Academy of Sciences, Guangzhou, China, Post Code: 510640), CAO Hai-liang (College of Chemical Engineering, Zhengzhou University, Zhengzhou, China, Post Code: 450001) // Journal of Engineering for Thermal Energy & Power — 2010, 25(2). — 134 ~ 140

Through a numerical solution of the Reynolds number time-averaged 3-D steady viscous N-S equation and in conjunction with a RNG  $k-\epsilon$  turbulent flow model and a non-equilibrium wall surface function, numerically simulated was the flow state in the rotating cascade of an ultramicro radial turbine. As a result, the influence of the rotating cascade blade tip clearance with an extremely low aspect ratio on the parameter distribution and aerodynamic losses of the flow field was revealed, providing a theoretical basis for the design and improvement of ultramicro turbines. The simulation results show that the magnitude of the blade tip clearance exercises a major influence on the distribution of Mach number inside the flow passages. Among others, the mixing and dilution of the leakage vortex with main streams caused by the jet flow from the blade tip clearance constitutes the major cause for a decrease in Mach number of the main stream. The existence of the blade tip clearance makes the total pressure loss coefficients homogeneous, i.e., the total pressure losses in both the wall-neighbor region and main stream zone are relatively high. The pad on the rotating cascade along the blade span direction assumes a uniform distribution, and the pad in the chord direction is mainly undertaken by the arc segment close to the trailing edge. During the simulation, a three-dimensional wake vortex was identified through an analysis. This is mainly caused by an excessively thick trailing edge of the rotating cascade, making it necessary to improve the blade profile. Key words: ultramicro turbine, blade tip clearance, rotating cascade, aspect ratio, numerical simulation

边界元法在气冷涡轮叶栅气热耦合计算中的应用 = Application of Boundary Element Method in the Gas-thermal Coupled Calculation of an Air-cooled Turbine Cascade [刊, 汉] / WANG Zhen-feng, HUANG Hong-yun, TANG Hong-fei, HAN Wan-jin (College of Energy Science and Engineering, Harbin Institute of Technology

Harbin, China, Post Code: 150001) // Journal of Engineering for Thermal Energy & Power — 2010, 25(2). — 141 ~ 144

A boundary element calculation method was used in a program for solving a three-dimensional N-S equation. The finite difference method was adopted in the fluid portion of the coupled calculation program to solve the N-S equation, and the boundary element method to solve the heat conduction equation for the solid zone. A newly-developed gas thermal coupled calculation program was employed to conduct a gas thermal coupled analysis of the thermal environment in NASA-Mark II HP air cooled turbine cascades. By utilizing the advantages (features combining a decrease in dimension with analysis and discreteness) specific to the boundary element method, the authors have avoided the grid generation in the solid area and the solution seeking of interior nodes, thus enhancing the calculation precision. The calculation results show that the coupled calculation program can effectively and accurately solve the gas thermal coupled problems in multiple fields. The results of calculation correspond relatively well with those of the test ones, and their average error is assessed at 3%. Key words: gas thermal coupling; boundary element method; finite difference method; gas turbine; air cooling; coupled calculation

弹性环刚度强度的分析方法与力学特性研究 = Study of the Methods for Analyzing the Rigidity and Strength of an Elastic Ring and Its Mechanics Characteristics [刊, 汉] / LONG Xiangyang, HONG Jie, ZHANG Da-yi, LN Haiying (College of Energy Source and Power Engineering, Beijing University of Aeronautics and Astronautics, Beijing, China, Post Code: 100191) // Journal of Engineering for Thermal Energy & Power — 2010, 25(2). — 145 ~ 149

The rigidity parameter of an elastic ring represents an important constant for analyzing the kinetic characteristics of a rotor system and designing its critical speed. Proceeding from the requirements for various analyses, the authors have studied a finite element method for analyzing the structural rigidity of the elastic ring. Through experimental tests and measurements, the feasibility and accuracy of the finite element method for calculating the supporting rigidity of the elastic ring have been verified. From the requirements for structural design, the authors have also studied the strength characteristics, summarizing the key parameters for structural design of the rigidity and strength of the elastic ring and their influencing laws, thereby providing a basis for the kinetic design of the elastic ring. The main parameters being considered in a rigidity design should include the number of bosses, wall thickness and width, while those in a strength design mainly involve the number of bosses, wall thickness and transition fillets. Key words: elastic ring; rigidity; strength; finite element; rotor system

燃料电池/燃气轮机混合动力系统中催化燃烧室特性分析 = Characteristic Analysis of a Catalytic Combustor in a Fuel Cell/Gas Turbine Hybrid Power System [刊, 汉] / LIU Aiguo, WENG Yi-wu (Education Ministry Key Laboratory on Power and Mechanical Engineering, Shanghai Jiaotong University, Shanghai, China, Post Code: 200240) // Journal of Engineering for Thermal Energy & Power — 2010, 25(2). — 150 ~ 154

An experimental and theoretical analysis was conducted of a catalytic combustor in a metal carbonated fuel cell/micro gas turbine (MCFC/MGT) hybrid power system. Through an experimental analysis, determined was the influence of the inlet temperature and fuel concentration of the combustor on the fuel conversion rate, and in the meantime, the correctness of the mathematical model being used was also verified. When the hybrid power system is operating at off-design conditions, the inlet condition of its catalytic combustor may undergo a change. A mathematical model was used to analyze the influence of various main factors on the operation characteristics of the catalytic combustor. The research results show that the maximal error between the calculated results and the test ones is within a